

REV#	REVISION DESCRIPTION	DATE	APPROVED

DATE	CALCULATE POLYMER	ACTUAL POLYMER	SHOT TIME	SHOT	APPEED
xx	xxml				

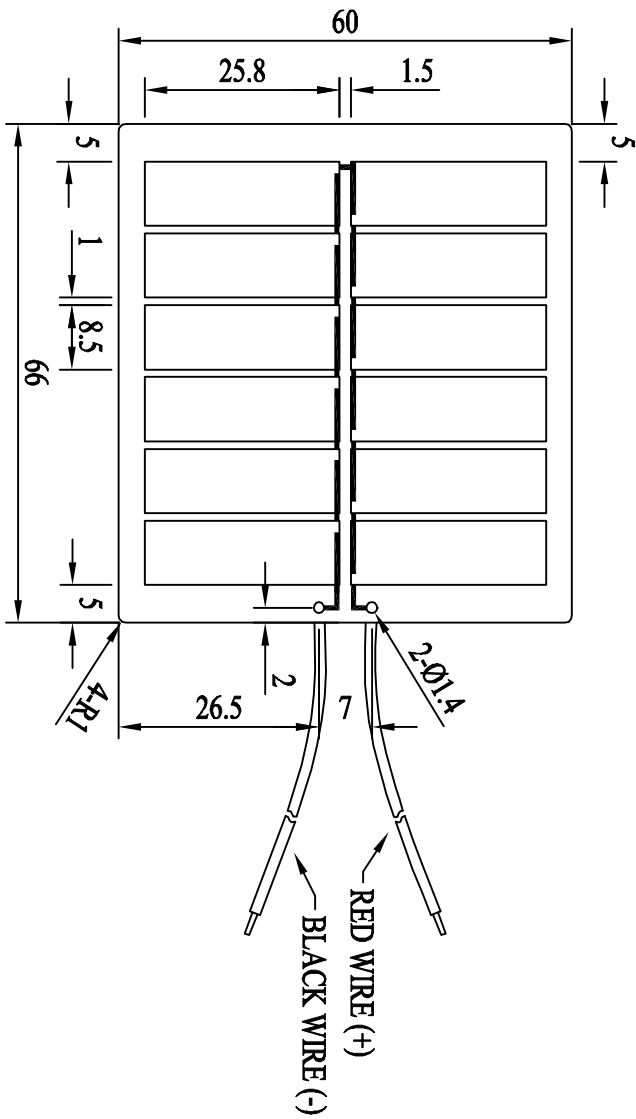

CO/CUSTOMER: DESCRIPTION/PRODUCT:
0.37W Solar Panel

STUDIO DEL SOLE INC.

PRODUCT MODEL: FP-PNL-XX
SUBSTRATE: FR4 1.0mm
SIZE: 66X60
COLOR: OPAQUE

FILENAME: PSLM 5.8-64.5
CABLE AWG#: 26 R/B S-WIRE
DWG. NO: XX REV.01
COLOR: OPAQUE
FILENAME: PSLM 5.8-64.5
CABLE AWG#: 26 R/B S-WIRE
DWG. BY: Sumlo 14-Aug-2006
SCALE: 1:1

APP. BY: Eddie 14-Aug-2006
UNIT: mm

Spe tolerance: ±10% (VP Jp)	
Cell: SCSMMS31N-B0085X0258	
Cell Efficiency: 15%	
Mc	12 pcs
Voc	7.1 V
Vp	5.8 V
mAsc	67.7 mA
mAp	64.5 mA
Wp	0.37 W