

# Violetta Solargear VS12-B100LIM Battery Compartment

## Operating Instructions

Thank you very much for purchasing our product. Please read this manual thoroughly before using this product, and retain it for future reference in order to use the product safely, and to make the most of its features. If you use other products together with this product, please read the operating instructions of those products thoroughly before use as well.

### Product Summary

A LiFePO4 battery compartment for dust and waterproof mobile PV systems designed for powering a broad range of appliances. Composed of a combination of an ultra-thin, light and efficient solar panel and a compact, lightweight yet weather resistant battery compartment for versatility, expandability, portability, weather resistance and durability at low cost in disaster prevention, business, leisure and everyday living.

### Applications

Charging the built-in LiFePO4 battery by sunlight, and powering a broad range of appliances through AC100V pure sine wave (inverter outlet), DC5V (USB) or DC12V (charge controller terminals or dust and water proof connectors). A built-in nightlight function can control DC12V load such as LED light at night.

### Features

- An IP67 dust and water proof Pelican Case with a fail-safe automatic pressure equalization valve as the battery compartment. Equipped with a retractable extension handle and strong polyurethane wheels with stainless steel bearings.
- A built-in state-of-the-art LiFePO4 battery ensures a lifespan of more than 4000 cycles.
- A built-in Denryo SA-BC20 charge controller with a nightlight function and with only 2mA of self-consumption current to protect the uncharged battery from over-discharging.
- IP68 dust and water proof connectors mating with solar panels, Extension Cables, DC12V Output Cables and DC Power Cables for weather resistant outdoor installations.
- A 1000W pure sine wave DC-AC inverter with 2 AC100V outlets and a DC5V USB receptacle for powering a broad range of appliances.
- Dust and water proof power supply to appliances with DC12V input with DC12V Output Cables (sold separately).
- 2 input connectors in parallel for 180W or smaller solar panels for quick charging.
- 2 input connectors for DC Power Cables (sold separately) to double the output capacity.

### Important Safety Instructions

**Caution** Please follow the instructions below. Failure to comply may damage this device, cause the built-in battery to burst or result in leakage, fire and injury.

- Charge only the specified batteries.
- Do not allow metal objects to touch the input/output connectors.
- Do not block the automatic pressure equalization valve on the battery compartment.
- Do not short circuit, or disassemble this device.
- Do not put this device into water.
- Do not use or leave this device near fire.
- Do not use or leave this device in enclosed spaces.
- Do not use or leave this device in unstable high places.
- Stop charging in case of leakage from the battery.
- Stop charging in case the battery becomes unusually hot.

### Important Note

We are not responsible for any physical damage to appliances, any loss of memorized data, any interruption of business, and any loss of business opportunities caused by this product.

### Specifications

- Built-in battery: RBT100LFP12S LiFePO4 battery
- Nominal capacity\*: 1200Wh (12V 100Ah)
- Cycle life\*: 4000 cycles
- Max output: \*
  - 1000W (AC100V inverter outlet)
  - 2.1A (DC5V USB)
  - 20A (DC12V charge controller terminals)
  - 17A (DC12V dust and water proof connectors)
- Operating temperature (charge)\*\*: -10 - 50°C
- Operating temperature (discharge)\*\*: 0 - 40°C (AC100V, DC5V USB)
- -15 - 60°C (DC12V)
- Dimensions (WXDXH): 500X305X457mm
- Weight: approx. 22.3kg (incl. accessories)
- Input/output terminals: IP68 dust and water proof connector X 2
- Output terminals:
  - AC100V inverter outlet X 2
  - DC5V USB receptacle X 1
  - DC12V charge controller terminals X 1
  - Denryo SA-BC20 charge controller
  - 20A fuse for short circuit prevention X 2
  - Schottkey diode for reverse current prevention X 2
  - 1000W pure sine wave DC-AC inverter
- Accessories:
  - \*0.2C rate at 25°C 80% DOD \*\*No freezing

### Feature Diagram

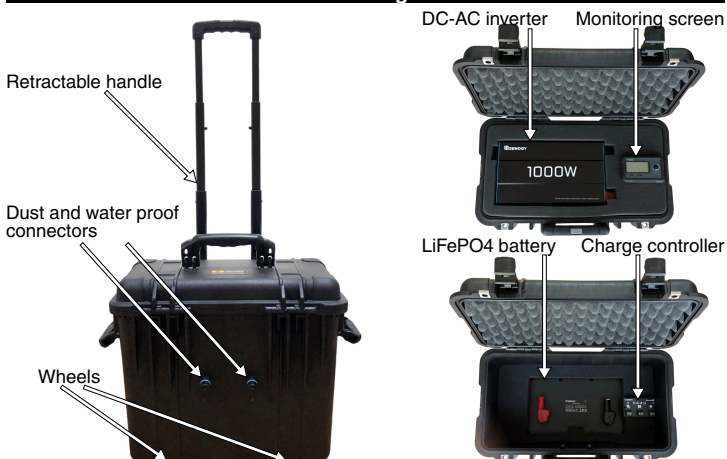

### How to Use

#### Connecting the solar panel/AC battery charger

- 1 Connect the output cables of the solar panel or AC battery charger to this product. Screw anticlockwise the cover off one of the dust and water proof connectors. Align the ▲ marks of both connectors and screw the ring clockwise tightly by hand.

**Note:** Pull the connectors lightly to make sure they are locked.



- 2 Press the Power button on the monitoring screen to activate the battery. The backlight will then be lit and the LCD Display will show the present voltage.

#### Charging the built-in Battery

- 1 Face the solar panel towards the sunlight, and charge the built-in battery. To mount the solar panel on the fence or on the ground, s-hooks, fixing ties or fixing pegs can be used. For the most efficient charging, adjust the direction and angle of the solar panel 90 degrees in opposition to the sun rays. Use the AC battery charger in the night and in bad weather.

#### Powering Appliances

- 1 After charging the built-in battery, open the lid and take out the provided DC-AC inverter.
- Note:** You do not need to fully charge the built-in battery before powering appliances, but the operating time varies widely depending on the battery status and the power consumption of appliances.
- 2 To power appliances with AC100V or DC5V input, turn on the provided DC-AC inverter, and connect the appliances to the inverter.
- 3 To power appliances with DC12V input indoors at night, connect the input cables of the appliance to the load terminals of the controller.
- 4 To power appliances with DC12V input outdoors, connect the DC12V Output Cables to dust and water proof connectors and the processed end to the appliances.
- Note:** To power appliances with the nightlight function and over-discharging protection of the charge controller effective, disconnect cables from the battery terminals, and connect them to the DC12V load terminals of the built-in charge controller.

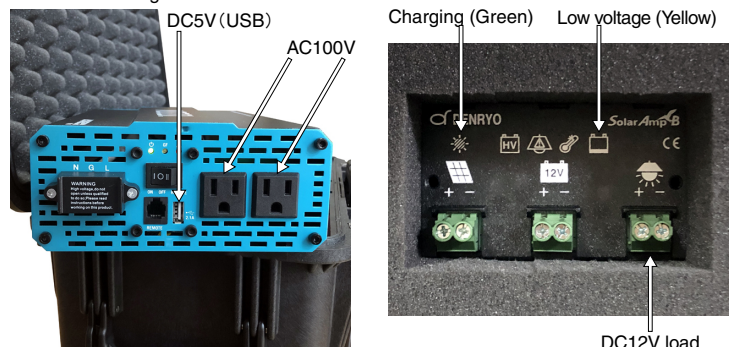

- 5 To monitor the status of the solar panel and the battery, refer to the LCD Display of the monitoring screen or to the LED indicators of the charge controller. Please refer to the instruction manual of the monitoring screen or the charge controller for details.
- 6 After you have finished powering appliances with AC100V or DC5V input, turn off the provided DC-AC inverter, and disconnect the appliance from the inverter. After you have finished powering appliances with DC12V input, disconnect the input cables of the appliance from the load terminals of the controller or from dust and water proof connectors.
- 7 Once you have finished powering appliances, press the Power button on the monitoring screen for 3 seconds to put the battery into shelf mode to protect the built-in battery from over-discharging. To keep away from dust and water, and to avoid short circuit, close the lid of the battery compartment and cover the dust and water proof connectors.
- 8 You can connect another battery compartment with DC Power Cables to double the output capacity to power appliances. 2 cables required to power appliances with power consumption of 200W to 400W.
- Note:** You cannot use DC Power Cables to power appliances with power consumption of over 400W.

### Maintenance

- To protect the built-in battery from over-discharging, charge it immediately when the charge controller indicates low voltage (yellow LED), or charge it at least every 6 month.
- The life of the built-in battery varies widely depending on the operating environment. Replace the battery when the operating time becomes notably short.
- Clean this product with a dried or dampened cloth. Do not use oil, solvents, petrol or paint thinners for cleaning.

### Warranty

- 1 year from the date of purchase

### STUDIO DEL SOLE INC.

1-101, City Court Meguro, 2-10-34, Kamiosaki, Shinagawa-ku, Tokyo 141-0021, Japan.  
Tel: +81-3-5423-6801 Fax: +81-3-5423-6802 E-mail: support@violetta.com

### www.violetta.com

Design and specifications are subject to change without notice.

Assembled in Japan 01-09-20