

MAX 92.5

300±10

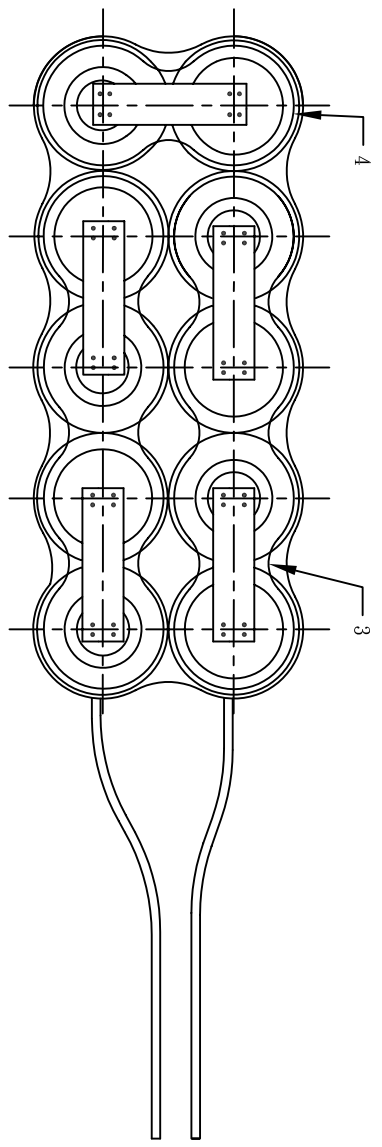
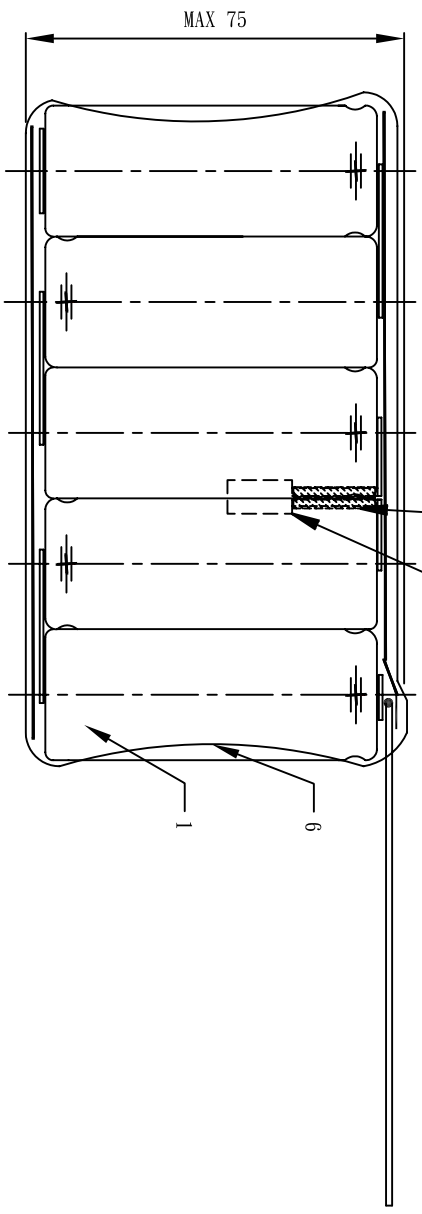
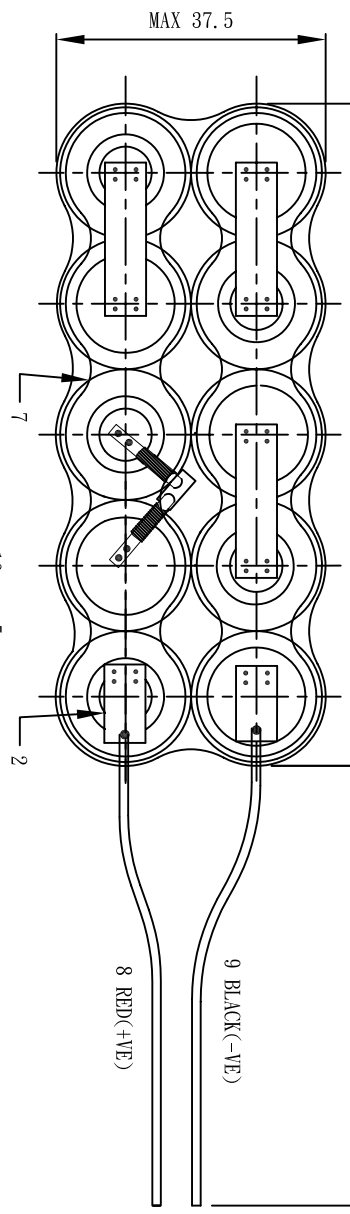

REVISIONS			
LTR	DESCRIPTION	SIGNATURE AND DATE	
		DWN	CHK AUTH

CIRCUIT DIAGRAM:

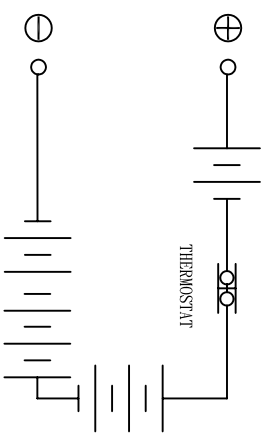

10	SHRINK020	HEAT SHRINK TUBE, BLACK
9	WIRE20UL1015B	WIRE: AWG#20, UL1015, BLACK
8	WIRE20UL1015R	WIRE: AWG#20, UL1015, RED
7	LAS5FR020	FIBRE PAPER, RED
6	SHRINK10110W	SHRINKAGE SLEEVE, WHITE
5	IP405BC-B75C	THERMOSTAT(75 °C)
4	LA2BFR020	FIBRE PAPER, RED
3	LA4BFR020	FIBRE PAPER, RED
2	NS15050	WELDING TAG
1	NT400LAHT	UNIT CELL

STUDIO DEL SOLE INC.

TITLE: LA SIZE PACK CONFIGURATION (10Y6Z)

DWG NO.: PRE0432 REV. NO.: 0

DIMENSIONS ARE IN mm AND INCLUDE PLATED FINISHES

SIGNATURE

DATE

Division : HZHM8

SCALE: Not in scale

NOTICE:
1.DO NOT SCALE THIS DRAWING
2.REMOVE ALL SHARP EDGE
UNLESS OTHERWISE SPECIFIED

DRAWN	MELON HE	21.Sep.10
CHKD	KEITH SUN	21.Sep.10
APPD	KCLEUNG	21.Sep.10

CELL TYPE: LA-SIZE
Page : 2 of 2

Manufacturer reserves the right to alter or amend the design, model and specification without prior notice.